



INTERNATIONAL ETHELLES CLASS EUROPEAN CHAMPIONSHIP 2-4 SEPTEMBER 2022

ORGANIZING AUTHORITY - ROYAL YACHT SQUADRON

SAILING INSTRUCTIONS

1. RULES

- 1.1. The event is governed by the rules as defined in the Racing Rules of Sailing (RRS).
- 1.2. See SI 9.6 for course signals in cross-tide wind conditions.
- 1.3. RRS 44.1 and RRS 44.2 are changed. See Notice of Race 14 'Penalty System'.
- 1.4. Appendix P will not apply.

2. CHANGES TO SAILING INSTRUCTIONS

- 2.1. Any changes to the sailing instructions will be posted before 0900 on the day it will take effect, except that any change to the schedule of races will be posted by 2000 on the day before it will take effect.

3. COMMUNICATIONS WITH COMPETITORS

- 3.1. Notices to competitors will be posted on the Official Notice Board (ONB) located online at www.yachtscoring.com.
- 3.2. The race office is located at Cowes Yacht Haven ('CYH'), at the Etchells containers - secretary@etchellsukfleet.co.uk.
- 3.3. On the water, the race committee intends to communicate with competitors on VHF radio channel 05. Competitors wishing to communicate with the Race Committee should do so on VHF Ch 77.
- 3.4. In addition, during the event a messaging service (Telegram, WhatsApp, SMS or other) will also be used to contact registered mobile numbers for each boat providing notifications and RC communications. Further details will be provided at registration. Failure to receive messages shall not be grounds for redress and changes RRS 62.1(a).

4. CODE OF CONDUCT

- 4.1. [DP] Competitors and support persons shall comply with reasonable requests from race officials.
- 4.2. Competitors shall handle any equipment provided by the organising authority with care, seamanship, in accordance with any instructions for its use and without interfering with its functionality.

5. SIGNALS MADE ASHORE

- 5.1. Signals made ashore will be displayed at Cowes Yacht Haven and advised on the event messaging service.
- 5.2. When flag AP is displayed ashore, '1 minute' is replaced with 'not less than 45 minutes' in Race Signals AP.

6. SCHEDULE OF RACES

- 6.1. See Notice of Race 9 'Schedule'
- 6.2. To alert boats that a race will begin soon, the orange starting line flag will be displayed on the committee signal vessel with multiple sound signals at least five minutes before a warning signal is made.

7. CLASS FLAG

- 7.1. The Etchells Class flag is white with the Etchells emblem.

8. RACING AREA

- 8.1. See Notice of Race 12 'Venue'.

9. COURSES

- 9.1. The diagrams in SI Addendum A show the courses, including the approximate angles between the legs, the order in which marks are to be passed, and the side on which each mark is left.
- 9.2. Soon after the orange flag attention signal is displayed, and before the warning signal, the race committee signal vessel will display the approximate bearing and distance to Mark 1. The course signal, compass bearing and distance to Mark 1 will also be announced on VHF.
- 9.4. If only a single windward or leeward mark is present, boats shall leave that mark to port before proceeding to the next mark of the course
- 9.5. Courses will not be shortened. This changes RRS 32.
- 9.6. In cross-tide wind conditions, after the first leg, subsequent legs of the course may be 'walked' down tide to achieve reasonable leeward and windward legs.

(a) Flag W will be displayed at or before the warning signal for a race where the course will be 'walked' down tide.

(b) When Flag W has been displayed, no course change signals (using Flag C) or new marks will be used except when leg length is being increased or decreased or the course is changed for a wind shift. This changes RRS Race Signals and RRS 33.

10. MARKS

- 10.1. Marks 1, 1a, 2p and 2s are orange inflatable pillar buoys.
- 10.2. The starting and finishing marks are race committee vessels at each end of the line.
- 10.3. New marks as provided in SI 13 are black marks.
 - (a) If Mark 1 is a new mark, Mark 1a will not be laid.
 - (b) If Marks 2p/2s are new marks, they will be two black marks.
- 10.4. A race committee vessel positioned near a mark will display a flag showing the colour of the next mark.

11. OBSTRUCTIONS

- 11.1. All boats shall comply with [Associated British Ports Notice to Mariners No 08 of 2022](#) giving details of a Precautionary Area and Moving Prohibited Zone (MPZ). The MPZ shall rank as an obstruction for the purposes of RRS 19 and 20.

12. THE START

- 12.1. Races will be started using RRS 26 with the warning signal made five (5) minutes before the starting signal.
- 12.2. The starting line is between staffs displaying orange flags on the starting marks.

All correspondence should be directed to:

The Royal Yacht Squadron, The Castle, Cowes, UK, PO31 7QT. Tel: 01983 292191, Email: mail@rys.org.uk

12.3. In addition to RRS 29.1, individual recalls may be broadcast on VHF, using bow or sail numbers. Failure to hail her number, failure of her to hear such a hail, or the order in which boats are hailed will not be grounds for a request for redress. This changes RRS 62.1(a).

12.4. A boat that does not start within five (5) minutes after her starting signal will be scored Did Not Start without a hearing. This changes RRS A5.1 and A5.2.

12.5 Bow numbers will be used for Uniform and Black Flag notifications. This changes RRS 30.3 and 30.4.

13. CHANGE OF NEXT LEG OF THE COURSE

13.1. To change the next leg of the course, the race committee will lay a new mark (or move the finishing line) and remove the original mark(s) as soon as practicable.

13.2. The race committee will announce details of any change under SI 13.1 using VHF Ch 05. Failure of a boat to hear such an announcement, will not be grounds for a request for redress. This changes RRS 62.1(a).

14. THE FINISH

14.1. The finishing line is between staffs displaying blue flags on the finishing marks.

15. PENALTY SYSTEM

15.1. See Notice of Race 14 'Penalty system'.

16. TIME LIMITS AND TARGET TIMES

16.1 The Mark 1 Time Limit, Race Time Limit (see RRS 35), and the Finishing Window are shown in the table below.

Mark 1 Time Limit	Race Target Time	Race Time Limit	Finishing Window
45 minutes	90 minutes	120 minutes	45 minutes

16.2 If no boat has passed the first mark within the Mark 1 Time Limit, the race will be abandoned.

16.3 The Finishing Window is the time for boats to finish after the first boat sails the course and finishes. Boats failing to finish within the Finishing Window, and not subsequently retiring, penalized or given redress, will be scored Time Limit Expired (TLE) without a hearing. A boat scored TLE shall be scored points for the finishing place one more than the points scored by the last boat that finished within the Finishing Window. This changes RRS 35, A5.1, A5.2 and A10.

16.4 Failure to meet the Target Time will not be grounds for redress. This changes RRS 62.1(a).

17. HEARING REQUESTS

17.1 The protest time limit is 90 minutes after the last boat finishes the last race of the day or the race committee signals no more racing today, whichever is later. The time will be posted on the official notice board.

17.2 Hearing request forms are available from the race office.

17.3 Notices will be posted no later than 30 minutes after the protest time limit to inform competitors of hearings in which they are parties or named as witnesses. Hearings will be held in the protest room, located at the Royal Yacht Squadron, beginning at the time posted.

18. SCORING

18.1 See Notice of Race 15 'Scoring'.

19. [DP] SAFETY REGULATIONS

19.1 A boat that retires from a race shall notify the race committee at the first reasonable opportunity.

20. REPLACEMENT OF CREW OR EQUIPMENT

20.1 [DP] Substitution of competitors is not allowed without prior written approval of the International Jury.

20.2 [DP] Substitution of damaged or lost equipment – requests for substitution shall be made to the committee at the first reasonable opportunity, which may be after the race.

21. EQUIPMENT AND MEASUREMENT CHECKS

21.1 See Notice of Race 10 'Equipment Inspection'.

21.2 [DP] When instructed by a race official on the water, a boat shall proceed to a designated area for inspection.

22. CHARTERED OR LOANED BOATS

22.1 See Notice of Race 17 'Chartered or loaned boats'.

23. OFFICIAL VESSELS

23.1 Official vessels will be identified as follows:

Race committee – white flag with letters 'RC'

Jury – flag with letters 'Jury'

24. [DP] SUPPORT TEAMS

24.1 See Notice of Race 16 'Support Person Vessels'.

25. TRASH DISPOSAL

25.1 Trash may be placed aboard official vessels.

26. BERTHING

26.1 See Notice of Race 18 'Berthing'.

27. LAUNCHING AND HAUL-OUT RESTRICTIONS

27.1 See Notice of Race 19 'Launching and haul out restrictions'.

28. DIVING EQUIPMENT AND PLASTIC POOLS

28.1 See Notice of Race 20 'Diving equipment and plastic pools'.

29. PRIZES

29.1 See Notice of Race 24 'Prizes'.

30. RISK STATEMENT

30.1 See Notice of Race 22 'Risk Statement'.

31. INSURANCE

31.1 See Notice of Race 23 'Insurance'.

End of Sailing Instructions

32. SOCIAL ARRANGEMENTS

The Etchells Class social event will take place at 1930 for 2000 on Saturday 3rd September – see event website for details.

ADDENDUM A - COURSE ILLUSTRATIONS

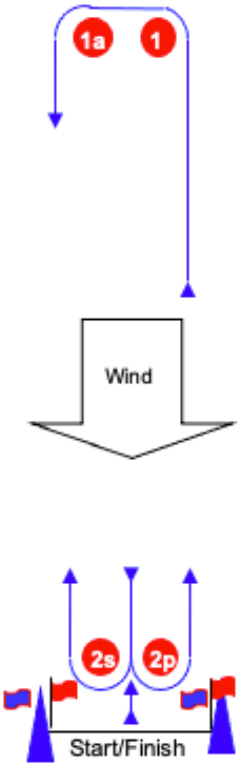
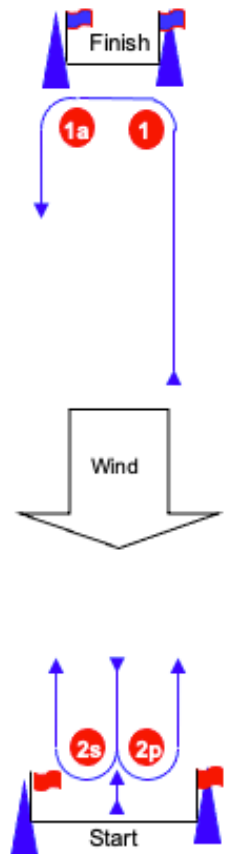
Course Illustrations – Windward Leeward with offset mark													
<div style="text-align: center; font-size: 2em; font-weight: bold; margin-bottom: 20px;">LA</div>  <p style="text-align: center; font-weight: bold; margin-top: 20px;">Course: Leeward finish</p> <table style="width: 100%; border-collapse: collapse;"> <thead> <tr> <th style="text-align: left; font-weight: normal;">Signal</th> <th style="text-align: left; font-weight: normal;">Mark Rounding Order</th> </tr> </thead> <tbody> <tr> <td>LA2</td> <td>Start - 1 - 1a - 2s/2p - 1 - 1a - Finish</td> </tr> <tr> <td>LA3</td> <td>Start - 1 - 1a - 2s/2p - 1 - 1a - 2s/2p - 1 - 1a - Finish</td> </tr> </tbody> </table>	Signal	Mark Rounding Order	LA2	Start - 1 - 1a - 2s/2p - 1 - 1a - Finish	LA3	Start - 1 - 1a - 2s/2p - 1 - 1a - 2s/2p - 1 - 1a - Finish	<div style="text-align: center; font-size: 2em; font-weight: bold; margin-bottom: 20px;">WA</div>  <p style="text-align: center; font-weight: bold; margin-top: 20px;">Course: Windward Finish</p> <table style="width: 100%; border-collapse: collapse;"> <thead> <tr> <th style="text-align: left; font-weight: normal;">Signal</th> <th style="text-align: left; font-weight: normal;">Mark Rounding Order</th> </tr> </thead> <tbody> <tr> <td>WA2</td> <td>Start - 1 - 1a - 2s/2p - Finish</td> </tr> <tr> <td>WA3</td> <td>Start - 1 - 1a - 2s/2p - 1 - 1a - 2s/2p - Finish</td> </tr> </tbody> </table>	Signal	Mark Rounding Order	WA2	Start - 1 - 1a - 2s/2p - Finish	WA3	Start - 1 - 1a - 2s/2p - 1 - 1a - 2s/2p - Finish
Signal	Mark Rounding Order												
LA2	Start - 1 - 1a - 2s/2p - 1 - 1a - Finish												
LA3	Start - 1 - 1a - 2s/2p - 1 - 1a - 2s/2p - 1 - 1a - Finish												
Signal	Mark Rounding Order												
WA2	Start - 1 - 1a - 2s/2p - Finish												
WA3	Start - 1 - 1a - 2s/2p - 1 - 1a - 2s/2p - Finish												